

Valve position indicator



Contents

A series
Part List

A series
Selection guide
Dimension

A series
Torque table

R series
Part list

R series
Selection guide
Dimension

R series
Torque table

Various option

Limit switch
box

Positioner

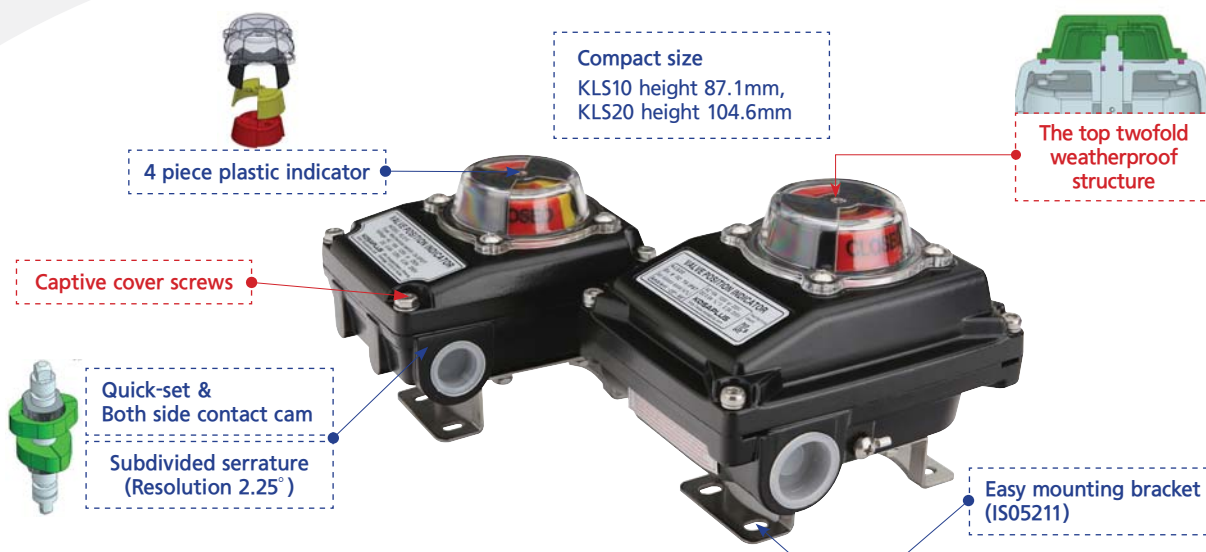

► Switch specification

- CSA, RU, VDE, KC Approved.	
Switch type	2*SPDT
Voltage	· AC 16A 125V or 250V · DC 0.6A 125V, 0.3A 250V
Enclosure protection	IP67, IP68

► Wiring

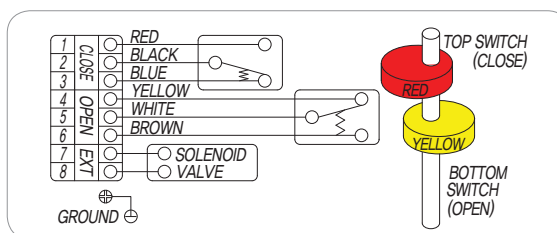

► Dimension

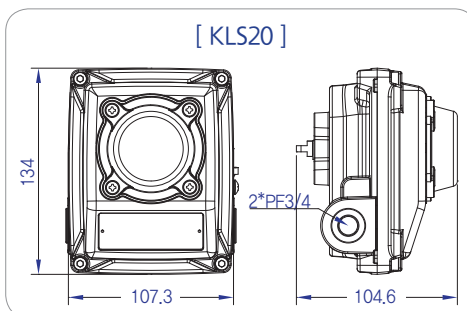
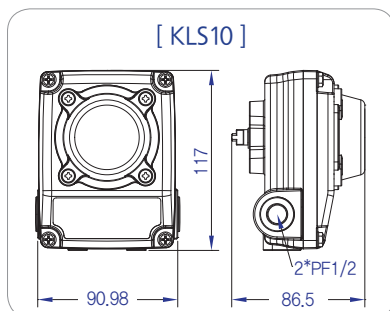

► Bracket

BS1	BS2	BS3	BS4
Size 50*25*20 (R40)	Size 30*80*20 (AR50~AR185)	Size 30*130*30 (AR210~A300)	Size 30*80(130)*20(30)(AR50~AR300)
Material Stainless steel	Material Stainless steel	Material Stainless steel	Material Stainless steel



Limit switch box

Contents

A series
Part List

A series
Selection guide
Dimension

A series
Torque table

R series
Part list

R series
Selection guide
Dimension

R series
Torque table

Various option

Limit switch
box

Positioner

► Specification

Allowable operation speed		0.1 m ~ 1 m/s		
Insulation resistance		Min 100M Ω (500 V d.c insulated ohmmeter)		
Contact resistance		Max 50 m Ω		
Dielectric strength	Between non-continuous terminal	AC 1,000V / 50~60Hz for 1 minute		
	Between each terminal and non-conduction metal part	AC 2,000V / 50~60Hz for 1 minute		
Vibration resistance		10~55Hz, double amplitude 1.5 mm		
Shock resistance	Destruction	Approx. 1,000 m/s ²		
	Malfunction	Approx. 300 m/s ²		
Mechanical life		2*SPDT		
Electrical life		Over 0.3 million operations (open/close frequency 20 times/min)		
Operating temp.		(open/close frequency 20 times/min)		
Operating humidity		45 ~ 85% RH		
Explosion proof type		Ex d IIC T6 IP67		
Rated voltage	Rated electro current (A)			
	Resistive load	Induction load	Electric motor load	
			N,C	N,O
AC 125 V	15	10	2	1
AC 250 V	10	6	1.5	0.75
DC 125 V	0.4	0.05	-	-
DC 250 V	0.2	0.03	-	-

► Label

PROTECTION GRADE	KU100 Ex d IIC T6 IP67 15-KB2BO-0071 (KTL) Ambient -10° ~ 60°
ELECTRIC RATING	125V - 10A 250V - 5A 125VDC - 0.8A 250VDC - 0.4A

► Wiring

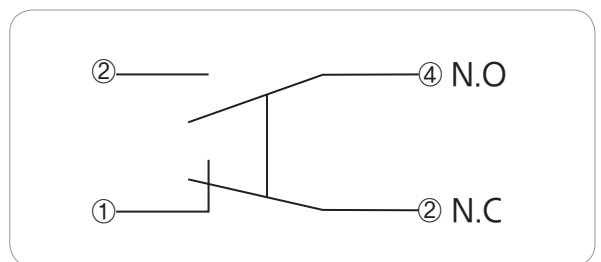

► Dimension

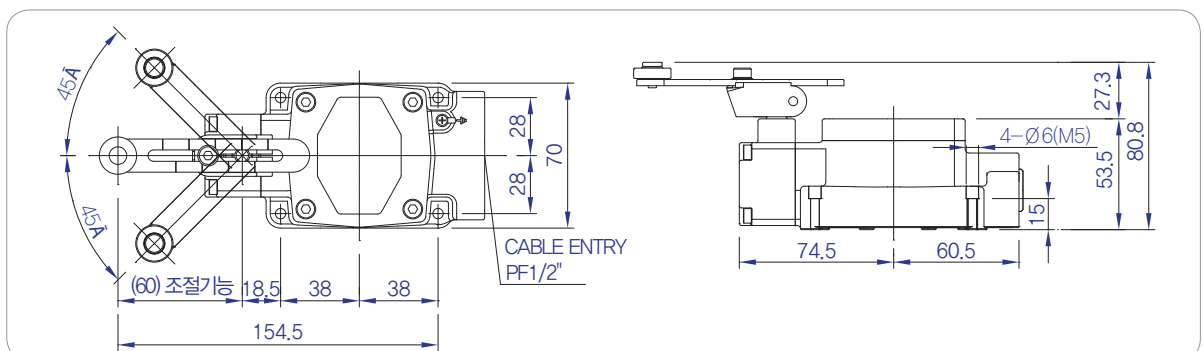

Positioner

Contents

A series
Part List

A series
Selection guide
Dimension

A series
Torque table

R series
Part list

R series
Selection guide
Dimension

R series
Torque table

Various option

Limit switch
box

Positioner



- Simple zero and span adjustment.
- Easy maintenance due to built-in module type.
- Strong to vibrations and No resonance between 5-200Hz.
- By-pass valve (A/M switch) installed.
- Air connection part is designed for detachability and it can be changed PF/NPT tapping threads in the field easily.

Type	KEP10L (Linear)		KEP10R (Rotary)	
	Single	Double	Single	Double
Input Signal	4~20mA DC			
Impedance	250±15Ω			
Supply Pressure	0.14~0.7MPa			
Stroke	10~150mm		0~90°	
Air Connection	PT 1/4 (NPT 1/4)			
Gauge Connection	PT 1/8 (NPT 1/8)			
Conduit	PF 1/2 (NPT 1/2)			
Explosion Proof	IP66			
Destruction	Operating Temp. -30°C~70°C (#L:-40°C~70°C/#H:-30°C~120°C)			
	Explosion Temp. -40°C~60°C(T5)/-40°C~40°C(T6)			
Linearity	±1.0% F.S	±2.0% F.S	±1.0% F.S	±2.0% F.S
Sensitivity	±0.2% F.S	±0.5% F.S	±0.2% F.S	±0.5% F.S
Hysteresis	±1.0% F.S			
Repeatability	±0.5% F.S			
Air Consumption	Blow 2.5LPM (Sup=0.14MPa)			
Flow Capacity	Over 80LPM (Sup=0.14MPa)			
Material	Aluminum Diecasting			
Weight	2.8Kg			

Model code : KEP @B©@E - ①			
@ Motion	L : Linear R : Rotary		
© Explosion	N : Non		
	B : Ex dmb II B		
	C : Ex dmb II C		
	A : Ex ia II C		
© Connection		Conduit	Air
	1:	PF1/2	PT1/4
	2:	PF1/2	NPT1/4
© Lever	Linear	1 : 10~40mm	
		4 : 40~70mm	
		7 : 70~100mm	
		0 : 100~150mm	
	Rotary	6 : M6*34L	
	N : Namur		
© Ambient Temp.	S : -30°C~70°C		
	L : -40°C~70°C		
	H : -30°C~120°C		
① Option	F : 4~20mA Feedback signal		
	L : Limit switch included (2xSPDT)		
	2 : Feedback+Limit switch		

-Tested under ambient temperature of 20°C, absolute pressure of 760mmHg, and humidity of 65%.

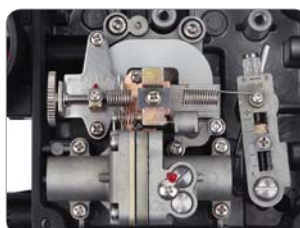
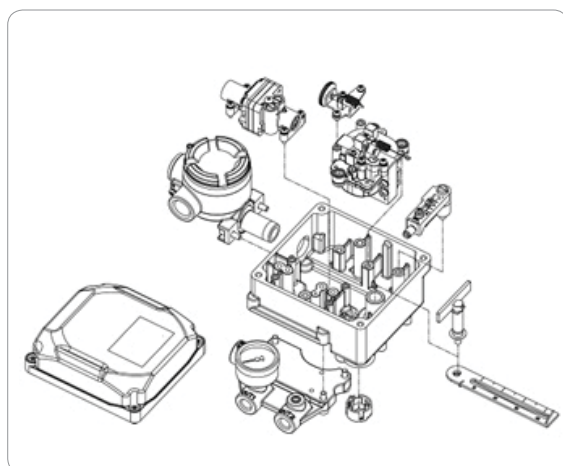

Contents

A series
Part List

A series
Selection guide
Dimension

A series
Torque table

R series
Part list

R series
Selection guide
Dimension

R series
Torque table

Various option

Limit switch
box

Positioner

▶ A series (scotch yoke) ISO5211 / Stem / Weight

MODEL	ISO5211	STEM	AD(Kg)	AS(Kg)
A50	F03/F05/F07	11*11	1.4	1.6
		#14*14		
		#9.7*15		
A65	F05/F07	14*14	2.3	3.0
		#11*11		
		#11.7*Ø17		
		#9.7*Ø15		
A80	F07	17*17	3.9	5.3
A100	F07/F10	#14.7*Ø19	6.7	9.5
		22*22		
A125	F07/F10	#17.7*Ø22	11.3	17.6
A140	F10/F12	27*27	16.4	23.9
		#22*22		
A160	F14	36*36	23.7	36.6
	#F10/F12	#27*27		
A185	F14	36*36	34.8	56.9
A210	F16	46*46	45.5	77.2
	#F14	#36*36		
A250	F16	46*46	65.8	119.6
A300	F16/F25	55*55	165	275.5

#Option

▶ R series (rack pinion) ISO5211 / Stem / Weight

MODEL	ISO5211	STEM	RD(Kg)	RS(Kg)
RD32	F03	9*9	0.3	-
R40	F03/F05	9*9	0.5	0.6
	#F04			
R50	F03/F05/F07	11*11	1.0	1.1
	#F04			
R65	F05/F07	14*14	1.4	1.5
	#F04/F07			
R80	F05/F07	17*17	2.9	3.3
R90	F07	17*17	3.4	3.8
R100	F07/F10	22*22	4.7	5.4
		#17*17		
R115	F07/F10	22*22	6.7	7.5
R125	F07/F10	22*22	8.6	9.9
R140	F10/F12	27*27	12.4	14.5
		#22*22		
R160	F10/F12	27*27	16.9	19.5
R185	F10/F12	36*36	24.2	29.0
R210	F14	36*36	32.3	37.9

#Option

KOSA PLUS

KOSAPLUS Co.,Ltd.

294, Gongdan2daero, Siheung, Gyeonggi, 15115, S.Korea (<http://www.kosaplus.com>)

· E-mail : oversea@kosaplus.com · Tel : +82-31-433-3159 / Fax : +82-31-433-3151

Catalog Version : 5.0 (Feb.2018)

- Data contained in the Catalog may be subject to change without advance notice for improvement of performance&safety of Product.

- Contact us for the most recent product and technical information. Visit our website for more details: <http://www.kosaplus.com>