

# RACK&PINION / SPRING RETURN / RS125

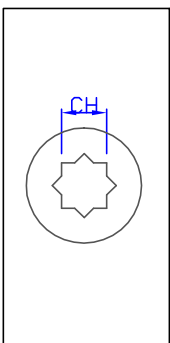

REV./NO.	REVISION DESCRIPTION	DRAWN / DATE	REVIEWED / DATE	APPROVED / DATE
△	12이 및 하부 덮개 수정	노을아 / 130619		
△	커버 하부 외형수정 /트럭데이터서체	노을아 / 170119		

Operating

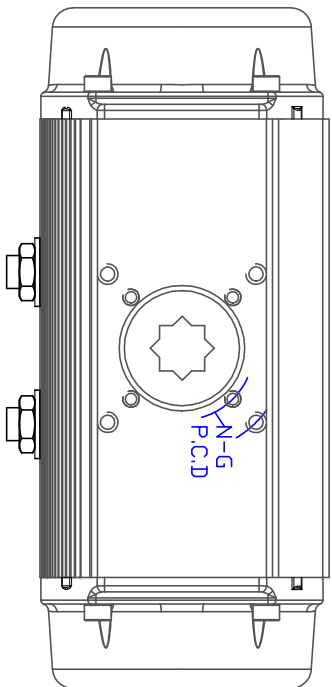
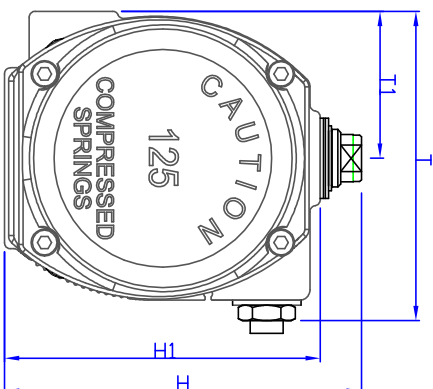
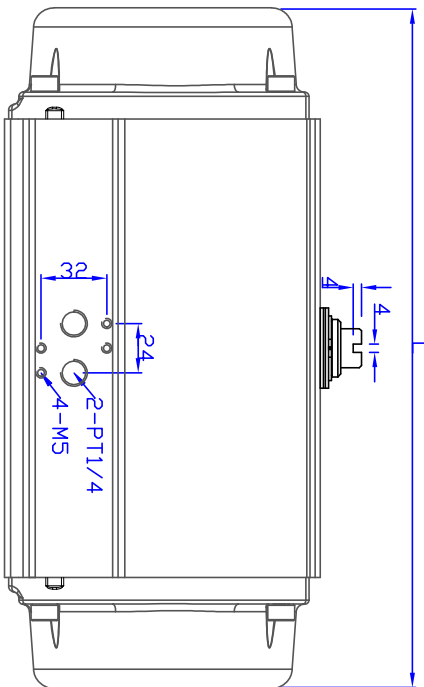
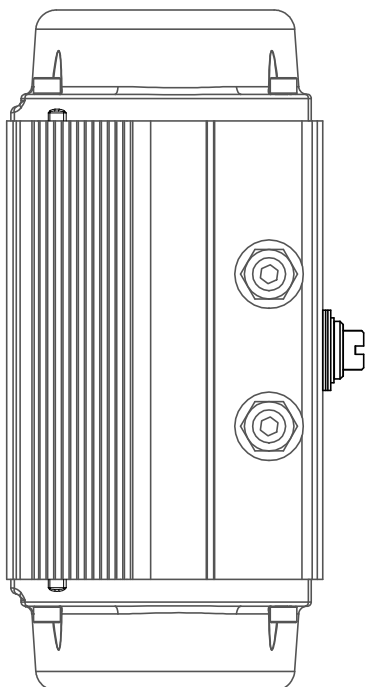
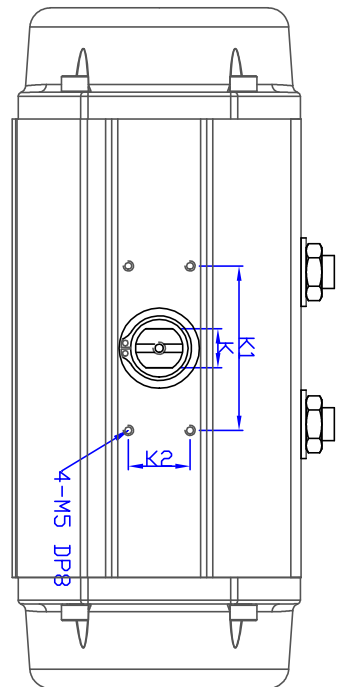
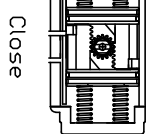
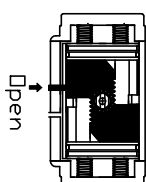

### MAJOR PART LIST

NO.	PART NAME	MATERIAL
1	BODY	ALUMINIUM
2	SHAFT	STEEL ALLOY (NICKEL COATING)
3	PISTON	ALUMINIUM
4	COVER	ALUMINIUM

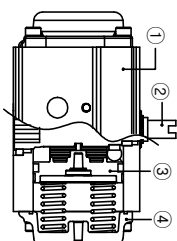

### SPECIFICATIONS

1. Operating fluid : Compressed dry air
2. Operating pressure : 4Bar~7Bar
3. Operating temperature : -20~80°

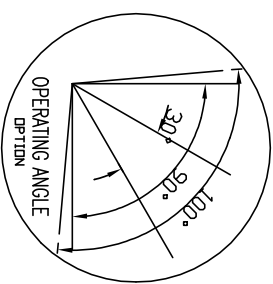
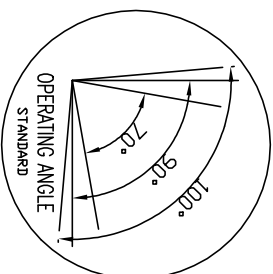

### ■ DIMENSION(mm)

MODEL	K1	K2	ISO	ØP.C.D	N-G(DP)	K	L	T	T1	H	H1	CH	DP	WEIGHT
RS125	80	30	F07/F10	70/102	4-M8/M10(16/19)	19	331	150.5	71.5	173.5	153.5	22*22	26	9.9kg

PRODUCT NAME		TITLE	
MODEL	Pneumatic actuator	MODEL	KOSAPLUS Co.,Ltd
MATERIAL	RS125	HARDNESS	
DRAWING DATE		APPROVED DATE	
DRAWING NO. PARS125-001		DRAWING NO. PARS125-001	
REV. 6		REV. 6	