

SCOTCH-YOKE / AS250

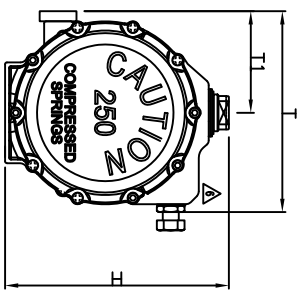

REV.NO.	REVISION DESCRIPTION	DRAWN / DATE	REVIEWED / DATE	APPROVED / DATE
△	바디 형상변경	노동아 / 171012		
△	바디 형상변경	노동아 / 171109		

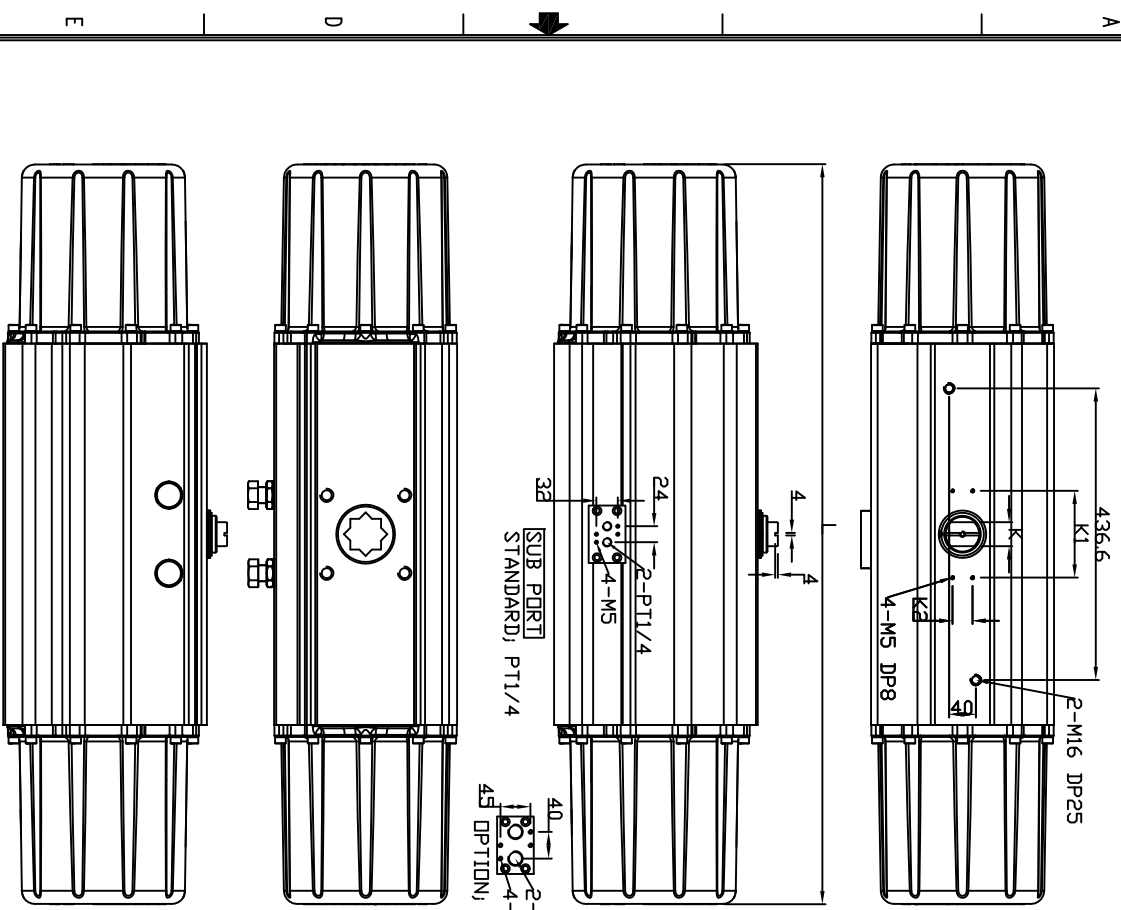
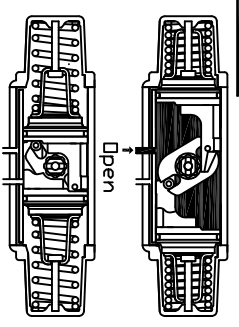

MAJOR PART LIST

NO.	PART NAME	MATERIAL
1	BODY	ALUMINIUM
2	SHAFT	STEEL ALLOY (NICKEL COATING)
3	SHAFT ROLLER	ENGINEERING PLASTIC
4	CRANK	STEEL ALLOY
5	PISTON	ALUMINIUM
6	COVER	ALUMINIUM

SPECIFICATIONS

1. Operating fluid : Compressed dry air
2. Operating pressure : 4Bar~7Bar
3. Operating temperature : -20~80°
4. Spring torque : Weak/Middle/Strong

DIMENSION(mm)		ISO	ØP.C.D	N-G(OP)	K	L	T	T1	H	H1	CH	DP	WEIGHT
MODEL	K1 K2	F16	165	4-M20 (29)	36	1108	301	152	335	305	46*46	60	119.8kg

PRODUCT NAME Pneumatic actuator		TITLE DRAWING	
MODEL AS250	HARDNESS -	DRAWING NO. PAAS250-001	
DRAWING DATE	APPROVED DATE	REV. 6	

KOSAPLUS Co.,Ltd